



# The Student Pilot's Flight Manual

From First Flight to Pilot Certificate



Based on the original text by  
**WILLIAM K. KERSHNER**

12th Edition Edited by William C. Kershner

**PRIVATE AND SPORT PILOTS**

# The Student Pilot's Flight Manual

From First Flight to Pilot Certificate

Based on the original text by

**WILLIAM K. KERSHNER**

12th Edition Edited by William C. Kershner

---



AVIATION SUPPLIES & ACADEMICS, INC.  
NEWCASTLE, WASHINGTON

*The Student Pilot's Flight Manual: From First Flight to Pilot Certificate*  
Twelfth Edition  
by William K. Kershner; edited by William C. Kershner

Aviation Supplies & Academics, Inc.  
7005 132nd Place SE  
Newcastle, Washington 98059  
asa@asa2fly.com | 425-235-1500 | asa2fly.com

Copyright © 2006–2025 Kershner Flight Manuals, LLC.  
Twelfth Edition published 2025 by Aviation Supplies & Academics, Inc.  
Previous editions © 1960–2001 by William K. Kershner.  
First edition published 1960 by Iowa State University Press.

All rights reserved. No part of this publication may be reproduced, stored in a retrieval system, or transmitted in any form or by any means without the prior written permission of the copyright holder. No part of this publication may be used in any manner for the purpose of training artificial intelligence systems or technologies. While every precaution has been taken in the preparation of this book, the publisher and Kershner Flight Manuals, LLC, assume no responsibility for damages resulting from the use of the information contained herein.

None of the material in this book supersedes any operational documents or procedures issued by the Federal Aviation Administration, aircraft and avionics manufacturers, flight schools, or the operators of aircraft.

URLs appearing in this book are active at the time of publication, but site content may have since changed, moved, or been deleted.

#### **ASA-FM-STU12**

ISBN 978-1-64425-408-0

Additional formats available:  
eBook EPUB ISBN 978-1-64425-409-7  
eBook PDF ISBN 978-1-64425-410-3

Printed in the United States of America

2029 2028 2027 2026 2025 9 8 7 6 5 4 3 2 1

Cover photo: William K. Kershner flies his Cessna 152 Aerobat, N7557L, near his home of Sewanee, Tennessee. This photo was taken by Mike Fizer on March 14th, 2000 for the 2001 AOPA calendar. Dad had over 7,000 separate spins of between 3 and 25 turns in his 22 years teaching aerobatics in this airplane. Two months after his death in January 2007, my son, Jim, and I were honored to deliver 57L to Dulles International Airport for display at the National Air and Space Museum's Steven F. Udvar-Hazy Center. — *William C. Kershner*

Photo credits: Front cover, top, courtesy of AOPA; front cover, bottom, simone c/AirTeamImages.com; photo under Dedication, page v, courtesy of Elizabeth Motlow.

#### *Library of Congress Cataloging-in-Publication Data*

Names: Kershner, William K., author. | Kershner, William C., editor.

Title: The student pilot's flight manual : from first flight to pilot certificate / original text by William K. Kershner, edited by William C. Kershner.

Description: 12th edition. | Newcastle, Washington : Aviation Supplies & Academics, Inc., 2025. | "ASA-FM-STU12"— Title page verso. | Includes bibliographical references and index.

Identifiers: LCCN 2024040643 (print) | LCCN 2024040644 (ebook) | ISBN 9781644254080 (trade paperback) | ISBN 9781644254097 (epub) | ISBN 9781644254103 (pdf)

Subjects: LCSH: Airplanes—Piloting. | Airplanes—Piloting—Handbooks, manuals, etc. | Emergency maneuvers (Aeronautics) | Cross-country flying. | Night flying. | LCGFT: Handbooks and manuals.

Classification: LCC TL710 .K43 2025 (print) | LCC TL710 (ebook) | DDC 629.132/52—dc23/eng/20240925

LC record available at <https://lccn.loc.gov/2024040643>

LC ebook record available at <https://lccn.loc.gov/2024040644>

# CONTENTS

---

Dedication . . . . .	v
About the Author . . . . .	vi
Acknowledgments . . . . .	vii
Preface . . . . .	viii

## **PART 1** Before the Flight

<b>chapter one</b> Starting to Fly . . . . .	3
<b>chapter two</b> The Airplane and How It Flies . . . . .	5
<b>chapter three</b> Flight Deck Instruments and Systems . . . . .	15
<b>chapter four</b> Preflight Check . . . . .	45
<b>chapter five</b> Starting the Airplane . . . . .	55
<b>chapter six</b> Taxiing . . . . .	59
<b>chapter seven</b> Pretakeoff Check . . . . .	67

## **PART 2** Presolo

<b>chapter eight</b> Effects of Controls . . . . .	75
<b>chapter nine</b> The Four Fundamentals . . . . .	81
<b>chapter ten</b> Elementary Precision Maneuvers . . . . .	95
<b>chapter eleven</b> Elementary Emergency Landings . . . . .	105
<b>chapter twelve</b> Stalls and Slow Flight . . . . .	107
<b>chapter thirteen</b> Takeoffs and Landings . . . . .	127

## **PART 3** Postsolo Maneuvers

<b>chapter fourteen</b> Advanced Stalls . . . . .	159
<b>chapter fifteen</b> Emergency Flying by Reference to Instruments . . . . .	165
<b>chapter sixteen</b> Postsolo Precision Maneuvers . . . . .	177
<b>chapter seventeen</b> Special Takeoff and Landing Procedures . . . . .	185
<b>chapter eighteen</b> High-Altitude Emergencies . . . . .	199

<b>PART 4</b>	<b>Cross-Country and Night Flying</b>	
chapter nineteen	The Navigation Idea . . . . .	207
chapter twenty	The Chart and Other Printed Aids . . . . .	221
chapter twenty-one	Using the Radio . . . . .	227
chapter twenty-two	Weather Information . . . . .	249
chapter twenty-three	The Cross-Country—Knowing Your Airplane . . . . .	271
chapter twenty-four	Navigation Planning . . . . .	289
chapter twenty-five	Flying the Cross-Country . . . . .	313
chapter twenty-six	Introduction to Night Flying . . . . .	323

<b>PART 5</b>	<b>The Knowledge and Practical (Flight) Tests</b>	
chapter twenty-seven	The Knowledge Test Review . . . . .	333
chapter twenty-eight	The Practical (Flight) Test . . . . .	339

<b>PART 6</b>	<b>Private Certificate Syllabus . . . . .</b>	<b>359</b>
---------------	---	------------

### Appendices

appendix A	<i>Chart Supplement</i> Excerpts and Legend . . . . .	453
appendix B	Added Notes on Engines and Other Systems . . . . .	475
appendix C	Sport Pilot Airplane, Single-Engine Land (ASEL) . . . . .	491
appendix D	Sectional Chart Excerpt . . . . .	493
	Bibliography and Recommended Reading . . . . .	497
	Index . . . . .	499



## Dedication

The 12th Edition of the *Student Pilot's Flight Manual* is dedicated to my parents:  
Elizabeth Ann Deyo Kershner (1933–2009) and William K. Kershner (1929–2007).



## About the Author

William K. Kershner began flying in 1945 at the age of fifteen, washing and propping airplanes to earn flying time. By this method he obtained the private, then the commercial and flight instructor certificates, becoming a flight instructor at nineteen. He spent four years as a naval aviator, most of the time as a pilot in a night fighter squadron, both shore and carrier based. He flew nearly three years as a corporation pilot and for four years worked for Piper Aircraft Corporation, demonstrating airplanes to the military, doing experimental flight-testing, and acting as special assistant to William T. Piper, Sr., president of the company. Bill Kershner held a degree in technical journalism from Iowa State University. While at the university he took courses in aerodynamics, performance, and stability and control. He held the airline transport pilot, commercial, and flight and ground instructor certificates and flew airplanes ranging from 40 hp Cubs to jet fighters. He is the author of *The Student Pilot's Flight Manual*, *The Instrument Flight Manual*, *The Advanced Pilot's Flight Manual*, *The Flight Instructor's Manual*, and *The Basic Aerobatic Manual*. Kershner operated an aerobatics school in Sewanee, Tennessee, using a Cessna 152 Aerobat. He received the 1992 General Aviation Flight Instructor of the Year Award at the state, regional, and national levels. The Ninety-Nines awarded him the 1994 Award of Merit. In 1998 he was inducted into the Flight Instructor Hall of Fame, in 2002 was installed in the Tennessee Aviation Hall of Fame, and in 2007 was inducted into the International Aerobatic Club Hall of Fame. William K. Kershner died January 8th, 2007.

Editor William C. Kershner received his early flight training from his father, William K. Kershner. He holds commercial, flight instructor and airline transport pilot certificates. Across his more than 15,000 hours of flight time, he has flown 22 types of airplanes, ranging in size from Cessna 150s to Boeing 777s. He retired from commercial aviation as a 737 check airman and lives near Sewanee, Tennessee, with his wife and younger son.

## Acknowledgments for the Twelfth Edition

I thank my wife, Donna, for her support and sound advice.

Editor Jenn Moore gave invaluable suggestions on how to get points across more clearly, and graphic designer Kelly Burch made striking updates to the illustrations in this edition.

Thanks to photographer David Andrews for the pictures of the Cub and Cessna 182 flight decks.

Chris Frasse, designated pilot examiner, allowed the photos of his Piper Cub. He also gave me insight in how a private pilot practical test can be run in a complex electronic flight deck, while still verifying an applicant's fundamental flying skills.

Flight instructor Nick Gould answered any number of questions about best practices in instruction and patiently listened to my countless airline stories.

And lastly, thanks to the late Jon Foote, airframe and powerplant mechanic, who taught me so much over the last few years as I assisted with the annual inspection on my Cessna 182.



## Preface to the Twelfth Edition

This book is written to cover the fundamentals of light-plane flying and emphasizes flying skills and knowledge that will cover a wide range of airplane types and sizes. For instance, crosswind landing techniques effective in a Cessna or Diamond can also work well in a Boeing 777 or turbo prop. And although technology has changed dramatically over the years, the basics of flying and good judgment have not.

This manual is not intended to just help the reader squeak by on the FAA Knowledge Test (written) and practical test (flight test or checkride), but to lay a foundation of solid knowledge for use in the everyday process of learning to fly airplanes. Even after thousands of hours in the air, most pilots still learn something on every flight.

The flight maneuvers are written in the probable order of introduction to the student. The spin is included to give the student pilot an idea of what the maneuver entails, and the dangers involved in an inadvertent low-altitude spin.

Although this book was originally written for the individual working toward the Private Pilot Certificate, ASEL (airplane, single-engine, land), it includes all the information necessary for the slightly more restrictive Sport or Recreational Pilot Certificates. For example, the sport pilot applicant will not require training in emergency instrument flight (Chapter 15) or night flying (Chapter 26). But the already certificated pilot can use this book in preparing for the flight review (14 CFR §61.56; required every 24 months). Referencing Chapters 27 and 28, along with a review of 14 CFR Parts 61 and 91, will bring the pilot back up to speed on subjects they have not touched on in a while.

You'll notice that the use of technology is not front-and-center in this manual. Although you'll be responsible for basic knowledge of any installed navigation systems, the practical test continues to focus on the basic skills of flying: controlling the airplane, using good judgment in choosing a course of action, and basic navigation using landmarks and a chart, electronic or paper. The FAA's *Private Pilot for Airplane Category Airman Certification Standards* (FAA-S-ACS-6) is the detailed guide for the practical test, containing a welcome emphasis on identifying the hazards to a particular flight, and minimizing them (risk management).

This manual is, of necessity, written in general terms, as seen in the often-changing areas of information and weather services. Because airplanes vary from type to type in the use of flaps, carburetor heat (if installed), spin recovery, and other procedures, the pilot's operating handbook (POH) or airplane flight manual (AFM) is the final guide for operation of your specific trainer. Of course, all the performance and navigation charts in this text are for reference and example only.

Pilots should have ready access to a few other important resources. I have found the bare minimum to be the *Aeronautical Information Manual (AIM)*, the Federal Aviation Regulations (Title 14 of the Code of Federal Regulations), and the *Aviation Weather Handbook (FAA-H-8083-28)*. The *Advanced Pilot's Flight Manual (Kershner)* is a good source for more detail on aerodynamics and for transition to more complex airplane types.

As you enter the general aviation world, you'll notice that the airplanes at a small airport are, on average, pretty old. Among the factors driving this are both the cost of new airplanes and the Federal Aviation Administration's airworthiness requirements for all certificated airplanes.

The requirement for an annual inspection (unsurprisingly called the "annual") for every airplane to be legally airworthy adds to the longevity of airplanes and the safety of flight. A census at one small airport showed an average age of 51 years for the 16 fully airworthy airplanes hangared there. The planes ranged from a 1946 Piper Cub with no electrical system to a one-year-old Cessna 172 with an autopilot and extremely capable instrument panel. The combination of older airplanes and advancing technology offers opportunities for owners to upgrade their older airplane to modern avionics (aviation electronics), as you will see in Chapter 3.

I will welcome any feedback offered on this 12th Edition of *The Student Pilot's Flight Manual*. Please contact me through ASA (email: [feedback@asa2fly.com](mailto:feedback@asa2fly.com)).

Flying is one of mankind's most rewarding and challenging endeavors. Every flight is different and most experienced pilots can tell of wonders they've seen that no ground-bound person will ever know.

William C. Kershner  
Sewanee, Tennessee

---

Part

1

Before  
the Flight

2

# STARTING TO FLY

---

There are many reasons why people want to start flying. Maybe you are a younger person who wants to make it a lifetime career or maybe you are a slightly more senior citizen who always wanted to fly but until now haven't had the money. Whether a man or woman, young or old, you still may have a few butterflies in your stomach while worrying about how you will like it or whether you can do it. That's a natural reaction.

What can you expect as you go through the private pilot training course? You can expect to work hard on most flights and to come down from some flights very tired and wet with perspiration, but with a feeling of having done something worthwhile. After others, you may consider forgetting the whole idea.

Okay, so there will be flights that don't go so well, no matter how well you get along with your instructor. The airplane will seem to have decided that it doesn't want to do what you want it to. The situation gets worse as the flight progresses and you end the session with a feeling that maybe you just aren't cut out to be a pilot. If you have a couple of these in a row, you should consider changing your schedule to early morning instead of later afternoon flights, or vice versa. You may have the idea that everybody but you is going through the course with no strain at all, but every person who's gone through a pilot training course has suffered some "learning plateaus" or has setbacks that can be discouraging.

After you start flying, you may at some point decide that it would be better for your learning process if you changed instructors. This happens with some people and is usually a no-fault situation, so don't worry about a change or two.

It's best if you get your FAA (Federal Aviation Administration) medical examination out of the way very shortly after you begin to fly or, if you think that you might have a problem, get it done before you start the lessons. The local flight instructors can give you names of nearby FAA aviation medical examiners.

How do you choose a flight school? You might visit a few in your area and see which one suits you best. Watch the instructors and students come and go to the airplanes. Are the instructors friendly, showing real interest in the students? There should be pre- and postflight briefings of students. You may not hear any of the details, but you can see that such briefings are happening. Talk to students currently flying at the various schools and get their opinions of the learning situation. One good hint about the quality of maintenance of the training airplanes is how clean they are. Usually an airplane that is clean externally is maintained well internally, though certainly there are exceptions to this.

What about the cost? It's a good idea to have money ahead so that you don't have to lay off and require a lot of reviewing from time to time. Some flight schools give a discount if you pay for several hours ahead of time.

You are about to set out on a very rewarding experience; for an overall look at flight training and future flying you might read the following.

## The Big Four

As you go through any flight program, you'll hear four terms used many times: headwork, air discipline, attitude toward flying, and priorities. You may be the smoothest pilot since airplanes were invented, but without having a good grip on these requirements, you won't last long.

### Headwork

For any pilot, private or professional, the most important thing is good headwork. Nobody cares if you slip or skid a little or maybe every once in a while land a mite harder than usual, but if you don't use your head—if you fly into bad weather or forget to check the fuel and have to land in a plowed field—you'll find people avoiding you. Later, as you progress in aviation and lead flights or fly passengers, it's a lot more comfortable for all concerned if they know you are a person who uses your head in flying. So as the sign says—THILK, er, think.

### Air Discipline

This is a broad term, but generally it means having control of the aircraft and yourself at all times. Are you a precise pilot or do you wander around during maneuvers? Do you see a sports car and decide to buzz it? Air discipline is difficult at times. It's mighty tough not to fly over that good-looking member of the opposite sex who happens to be sunbathing right where you are doing S-turns across the road—but be strong!

More seriously, air discipline is knowing, and flying by, your own limitations. This means, for instance, canceling for bad weather and not risking yourself and your passengers.

It entails admitting when you are physically unfit due to illness or fatigue (a highly underrated threat) and not able to function well under the stress of an emergency. You'll need strength of character to resist any pressure to complete a flight and to fight "get-home-itis," the strong desire to fly that one last leg to home base. It also means honestly analyzing your flying faults and doing something about them. In short, air discipline means a mature approach to flying.

### Attitude

A good attitude toward flying is important. Most instructors will go all out to help someone who's really trying. Many an instructor's favorite story is about ol' Joe Blow who was pretty terrible at first but kept at it until he got the word and is now flying rockets for Trans-Galaxy Airlines. With a good attitude you will get plenty of help from everybody. More students have failed in flying because of poor headwork and attitude than for any other reason. This doesn't imply apple polishing. It does mean that you are interested in flying and study more about it than is required by law.

### Priorities

As you go through your flying career, whether flying strictly for enjoyment or as a professional pilot, it's critical to remember these top three priorities and their order of importance, aviate, navigate, and communicate.

- **Aviate:** first and foremost, fly the airplane using the flight controls and flight instruments.
- **Navigate:** determine where you are and/or where you need to go.
- **Communicate:** Speak with someone outside of the aircraft like air traffic control (ATC).

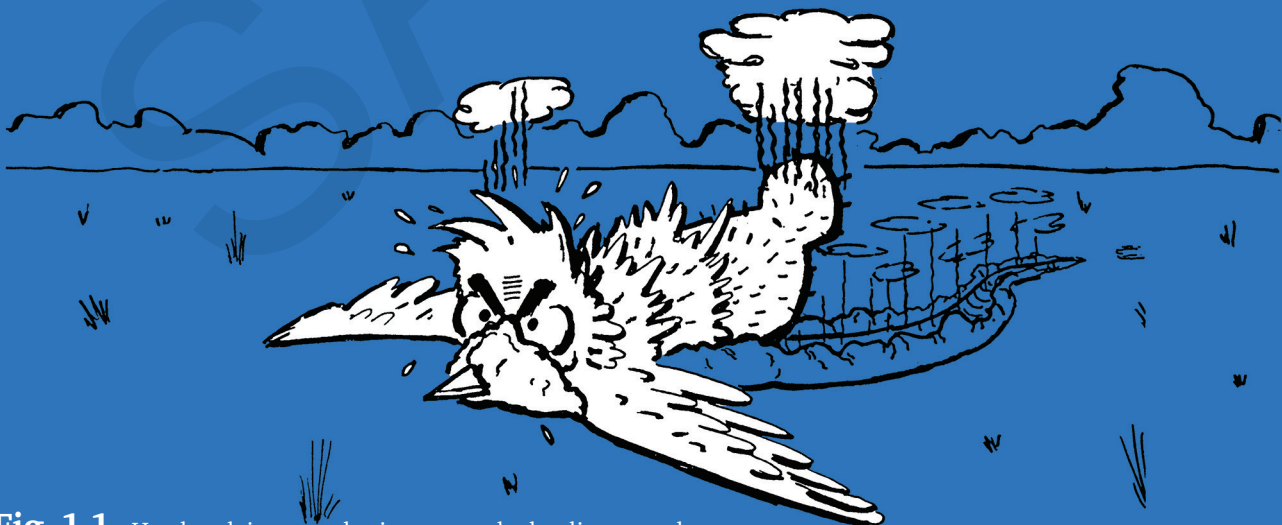
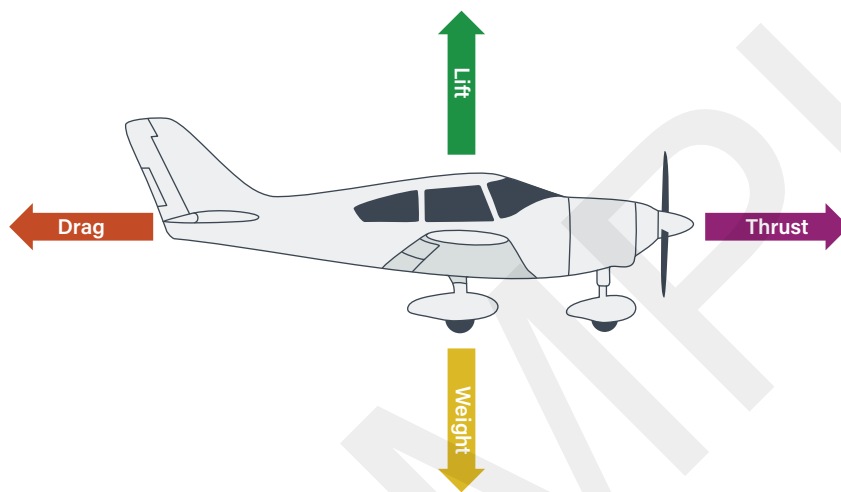


Fig. 1-1. Headwork is remembering to put the landing gear down.

# THE AIRPLANE AND HOW IT FLIES

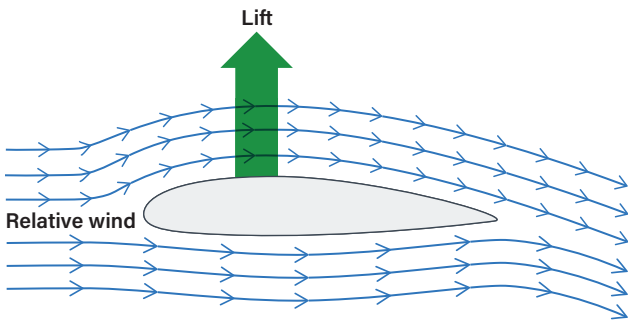
## The Four Forces

Four forces act on an airplane in flight: *lift*, *thrust*, *drag*, and *weight* (Figure 2-1).

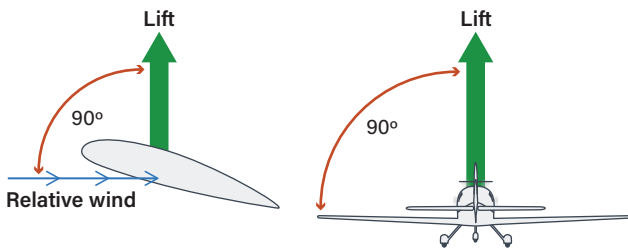


**Fig. 2-1.** The four forces. When the airplane is in equilibrium in straight and level cruising flight, the forces acting fore and aft (thrust and drag) are equal, as are those acting at 90° to the flight path (lift and weight, or its components).

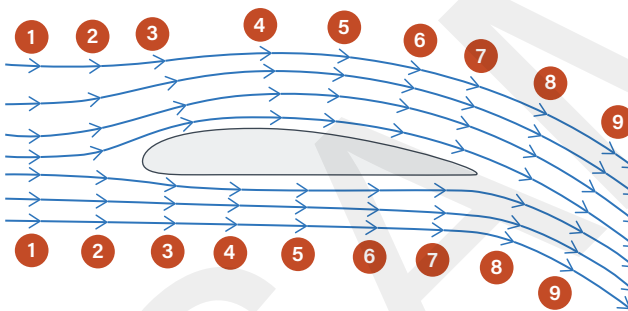




**Fig. 2-2.** The airfoil.



**Fig. 2-3.** Lift acts perpendicular to the relative wind and wingspan.



**Fig. 2-4.** Airflow past the airfoil.

## Lift

Lift is a force exerted by the wings. (Lift may also be exerted by the fuselage or other components, but at this point it would be best just to discuss the major source of the airplane’s lift, the wings.) It is a force created by the “airfoil,” the cross-sectional shape of the wing being moved through the air or, as in a wind tunnel, the air being moved past the wing. The result is the same in both cases. The “relative wind” (wind moving in relation to the wing and airplane) is a big factor in producing lift, although not the only one (Figure 2-2).

*Lift is always considered to be acting perpendicularly both to the wingspan and to the relative wind* (Figure 2-3). The reason for this consideration will be shown later as you are introduced to the various maneuvers.

As the wing moves through the air, either in gliding or powered flight, lift is produced. How lift is produced can probably be explained most simply by Bernoulli’s theorem, which briefly puts it this way: “The faster a fluid moves past an object, the less sidewise pressure is exerted on the body by the fluid.” The fluid in this case is air; the body is an airfoil. Take a look at Figure 2-4, which shows the relative wind approaching an airfoil, all neatly lined up in position 1. As it moves past the airfoil (or as the airfoil moves past it—take your choice), things begin to happen, as shown by the subsequent numbers.

The distance that the air must travel over the top is greater than that under the bottom. As the air moves over this greater distance, it speeds up to maintain equilibrium at the rear (trailing edge) of the airfoil. Because of this extra speed, the air exerts less sidewise pressure onto the top surface of the airfoil than on the bottom, and lift is produced. The pressure on the bottom of the airfoil is normally increased also, and you can think that, as an average, this contributes about 25 percent of the lift; this percentage varies with “angle of attack” (Figure 2-5).

Some people say, “Sure, I understand what makes a plane fly. There’s a vacuum on top of the wing that holds the airplane up.” Let’s see about that statement.

The standard sea level air pressure is 14.7 pounds per square inch (psi), or 2,116 pounds per square foot (psf). As an example, suppose an airplane weighs 2,000 pounds, has a wing area of 200 square feet, and is in level flight at sea level. (The wing area is that area you would see by looking directly down on the wing.) This means that for it to fly level (lift = weight) each square foot of wing must support 10 pounds of weight, or the wing loading is 10 pounds psf (2,000 divided by 200). Better expressed: There would have to be a difference in pressure of 10 pounds psf between the upper surface and the lower surface. This 10 psf figure is an average; on some portions of

the wing the difference will be greater, on others, less. Both surfaces of the wing can have a reduced sidewise pressure under certain conditions. However, the pressure on top still must average 10 psf less than that on the bottom to meet our requirements of level flight for the airplane mentioned. The sea level pressure is 2,116 pounds psf, and all that is needed is an average difference of 10 psf for the airplane to fly.

Assume for the sake of argument that, in this case, the 10 psf is obtained by an *increase* of 2.5 psf on the bottom surface and a *decrease* of 7.5 psf on the top (which gives a total difference of 10 psf). The top surface pressure varies from sea level pressure by 7.5 psf. Compared to the 2,116 psf of the air around it, this pressure reduction of 0.35 percent is certainly a long way from a vacuum, but it produces flight!

Note in Figures 2-2 and 2-4 that the airflow is deflected downward as it passes the wing. Newton's law, "For every action there is an equal and opposite reaction," also applies here. The wing deflects the airflow downward with a reaction of the airplane being sustained in flight. This can be easily seen by examining how a helicopter flies. Some engineers prefer Newton's law over Bernoulli's theorem.

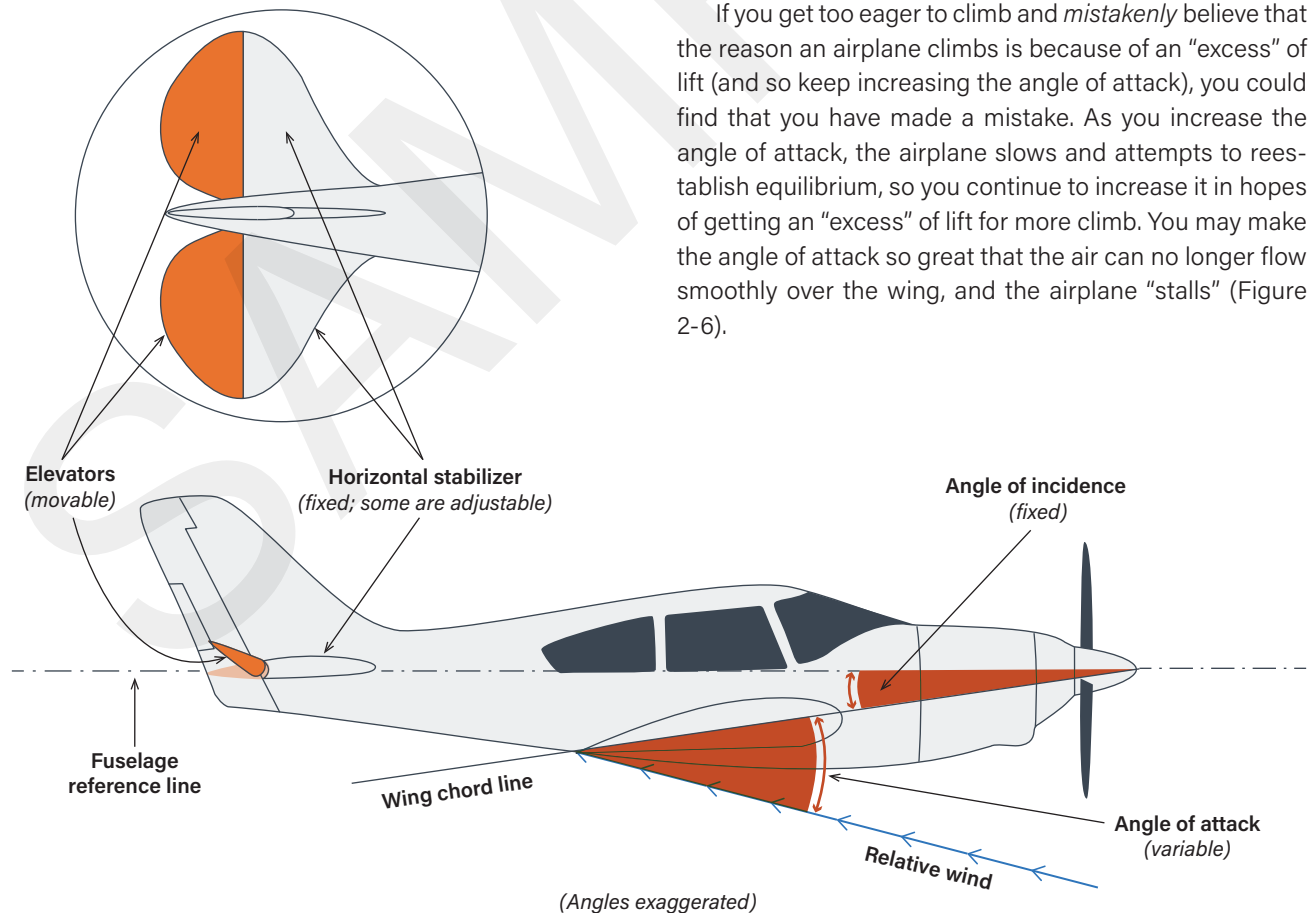
But the air *does* increase its velocity over the top of the wing (lowering the pressure), and the downwash also occurs. The downwash idea and how it affects the forces on the horizontal tail will be covered in Chapters 17 and 23.

### Angle of Attack

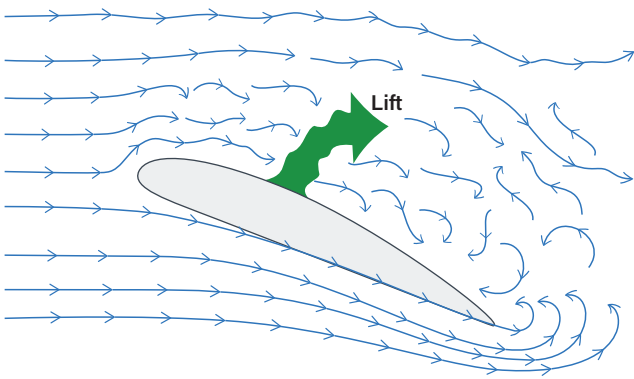
The *angle of attack* is the angle between the relative wind and the chord line of the airfoil. Don't confuse the angle of attack with the angle of *incidence*. The angle of *incidence* is the fixed angle between the wing chord line and the reference line of the fuselage. You'd better take a look at Figure 2-5 before this gets too confusing.

The pilot controls the angle of attack with the elevators. By easing back on the control wheel (also called the yoke) or the stick (whether it's a side stick or floor mounted), the elevator is moved up, as shown in Figure 2-5. The force of the relative wind moves the tail down, and because the wings are rigidly attached to the fuselage (you hope), they are rotated to a new angle with respect to the relative wind, a new *angle of attack*. At this new angle of attack the apparent curvature of the airfoil is greater, and for a very short period, lift is increased. But because of the higher angle of attack, more drag is produced, the airplane slows, and equilibrium exists again. (More about drag later.)

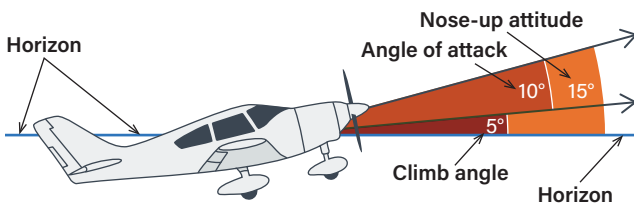
If you get too eager to climb and *mistakenly* believe that the reason an airplane climbs is because of an "excess" of lift (and so keep increasing the angle of attack), you could find that you have made a mistake. As you increase the angle of attack, the airplane slows and attempts to reestablish equilibrium, so you continue to increase it in hopes of getting an "excess" of lift for more climb. You may make the angle of attack so great that the air can no longer flow smoothly over the wing, and the airplane "stalls" (Figure 2-6).



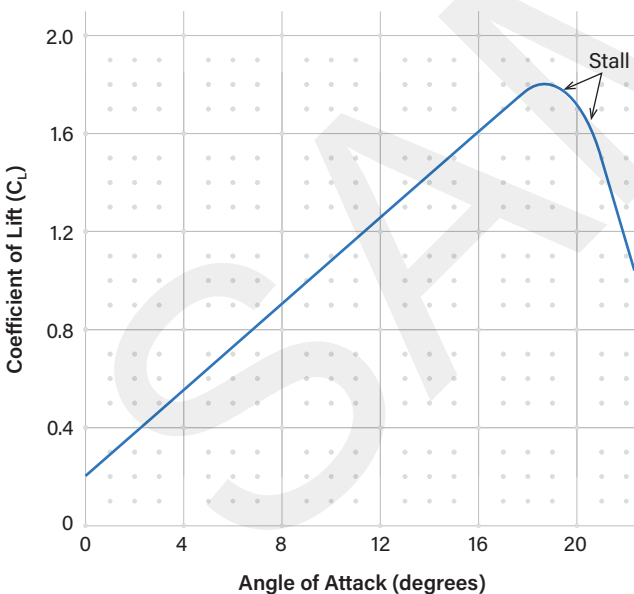
**Fig. 2-5.** Nomenclature.



**Fig. 2-6.** The stall.



**Fig. 2-7.** Pitch (nose-up) attitude, climb angle (flight path), and angle of attack.



**Fig. 2-8.** Relative lift increases with angle of attack until the critical angle of attack (stall angle) is reached. For this fictional airfoil it's about 19°.

It's not like a car stalling, in which case the engine stops; the airplane stall is a situation where the lift has broken down and the wing, in effect, is no longer doing its job of supporting the airplane in the usual manner. (The engine may be humming like a top throughout the stall.) There is still some lift, but not enough to support the airplane. You have forced the airplane away from the balanced situation you (and the airplane) want to maintain. For the airplane to recover from a stall, you must decrease the angle of attack so that smooth flow again occurs. In other words, point the plane where it's going! This is done with the elevators, the angle of attack (and speed) control (Figure 2-5). For most lightplane airfoils, the stalling angle of attack, called the critical angle of attack, is in the neighborhood of 15°–20°. Stalls will be covered more thoroughly in Chapters 12 and 14.

At first, the student is also confused concerning the *angle of attack* and airplane *attitude*. The attitude is how the plane looks in relation to the horizon. In Figure 2-7 the plane's attitude is 15° nose up, but it's climbing at an angle of 5°, so the angle of attack is only 10°.

In a slow glide the nose attitude may be approximately level and the angle of attack close to that of the stall. Later in your flying, you'll be introduced to the attitude of the wings (wing-down attitude, etc.), but for now only nose attitudes are of interest.

The coefficient of lift is a term used to denote the relative amounts of lift at various angles of attack for an airfoil. The plot of the coefficient of lift versus the angle of attack is a straight line, increasing with an increase in the angle of attack until the stalling angle is reached (Figure 2-8).

Lift depends on a combination of several factors. The equation for lift is:

$$L = C_L S \frac{\rho}{2} V^2, \text{ or } L = C_L \times S \times \frac{\rho}{2} \times V^2$$

where

L = lift, in pounds

C<sub>L</sub> = coefficient of lift (varies with the type of airfoil used and the angle of attack). The coefficient of lift, C<sub>L</sub>, is a dimensionless product and gives a *relative* look at the wings' action. The statement may be made in ground school that, "At this angle of attack, the coefficient of lift is point five (0.5)." Point five what? "Just point five, and it's one-half of the C<sub>L</sub> at one point zero (1.0)." Just take it as the relative effectiveness of the airfoils at a given angle of attack. Later, the coefficient of *drag* will be discussed.

S = wing area in square feet

$\frac{\rho}{2}$  = air density ( $\rho$ ) divided by 2. Rho ( $\rho$ ) is air density, which for standard sea level conditions is 0.002378 slugs per cubic foot. If you want to know the mass of an object in slugs, divide the weight by the acceleration of gravity, or 32.2. (The acceleration caused by gravity is 32.2 feet per second per second at the earth's surface.)

$V^2$  = velocity in feet per second squared

When you fly an airplane, you'll be working with a combination of  $C_L$  and velocity; but let's talk in pilot terms and say that you'll be working with a combination of angle of attack and airspeed. So lift depends on angle of attack, airspeed, wing area, and air density. For straight and level flight, lift equals weight. Assuming that your airplane weighs 2,000 pounds, 2,000 pounds of lift is required to maintain level flight. This means that the combination of the above factors must equal that value. The wing area ( $S$ ) is fixed, and the air density ( $\rho$ ) is fixed for any one time and altitude. Then  $C_L$  (angle of attack) and velocity (airspeed) can be worked in various combinations to maintain the 2,000 pounds of lift required. Flying at a low airspeed requires a high angle of attack, and vice versa. As the pilot you will control angle of attack and, by doing so, control the airspeed. You'll use power (or lack of power) with your chosen airspeed to obtain the desired performance.

While the factors of lift are being discussed, it might be well to say a little more about air density ( $\rho$ ). The air density decreases with increased altitude and/or temperature increase. Because of the decreased air density, airplanes require more runway for takeoff at airports of high elevation or on hot days. You can see in the lift equation that if the air is less dense, the airplane will have to move faster through the air in order to get the required value of lift for flight—and this takes more runway. (The airspeed mentioned is called "true airspeed" and will be discussed in more detail in Chapter 3.) Not only is the lift of the wing affected, but the less dense air results in less power developed within the engine. Since the propeller is nothing more than a rotating airfoil, it also loses "lift" (or, more properly, "thrust"). Taking off at high elevations or high temperatures can be a losing proposition, as some pilots have discovered after ignoring these factors and running out of runway.

Interestingly enough, you will find that lift tends to remain at an almost constant value during climbs, glides, or straight and level flight. *Don't* start off by thinking that the airplane glides because of decreased lift or climbs because of excess lift. *It just isn't so.*

## Thrust

Thrust is the second of the four forces and is furnished by a propeller or jet. The propeller is of principal interest to you at this point, however.

The theory of propellers is quite complicated, but Newton's "equal and opposite reaction" idea can be stated here. *The propeller takes a large mass of air and accelerates it rearward, resulting in the equal and opposite reaction of the plane moving forward.*

Maybe it's time a few terms such as "force" and "power" should be cleared up. Thrust is a *force* and, like the other three forces, is measured in pounds. A *force* can be defined as a tension, pressure, or weight. You don't necessarily have to move anything; you can exert force against a very heavy object and nothing moves. Or you can exert a force against a smaller object and it moves. When an object having force exerted upon it moves, *work* has been done.

*Work*, from an engineering point of view, is simply a measure of *force* times *distance*. And while at the end of a day of pushing against a brick wall or trying to lift a safe that won't budge, you feel tired, actually you've done no *work* at all. If you lift a 550-pound safe 1 foot off the floor, you'll have done 550 foot-pounds of *work* (and no doubt strained yourself in the bargain). If you lift a 50-pound weight to a height of 11 feet, you'll have done the same *work* whether you take all day or 1 second to do it—but you won't be developing as much *power* by taking all day. So the *power* used in lifting that 50 pounds up 11 feet, or 550 pounds up 1 foot, in 1 second would be expressed as:

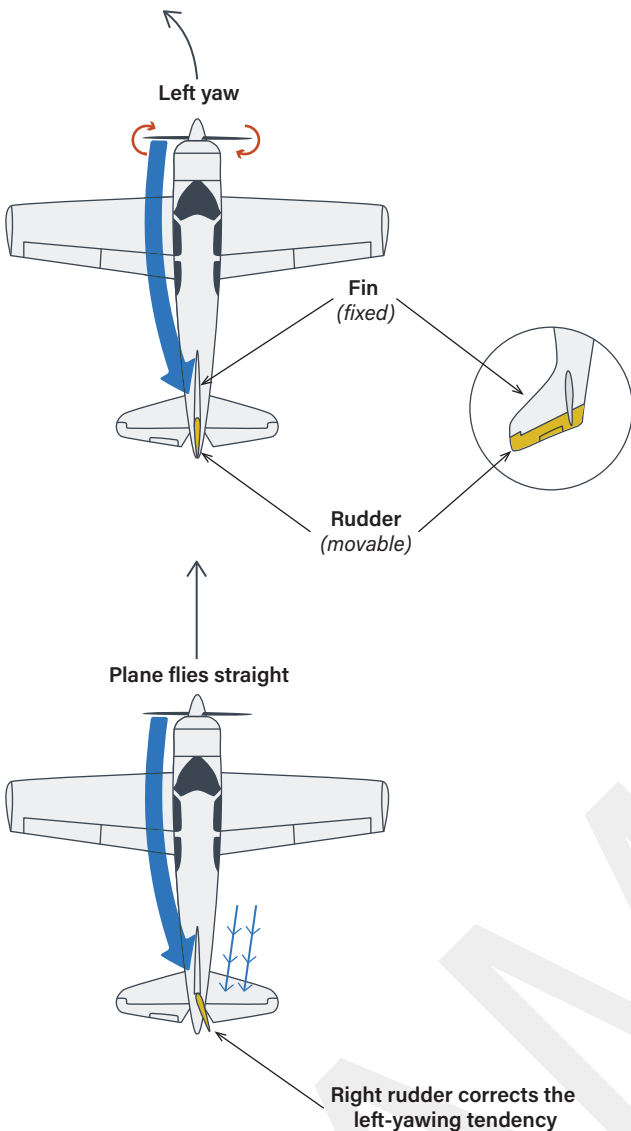
$$\text{Power} = 550 \text{ foot-pounds per second}$$

Obviously, this is leading somewhere, and you know that the most common measurement for power is the term "horsepower." One horsepower is equal to a power of 550 foot-pounds per second, or 33,000 foot-pounds per minute (60 seconds  $\times$  550). Whether the average horse of today can actually do this is not known, and unfortunately nobody really seems to care.

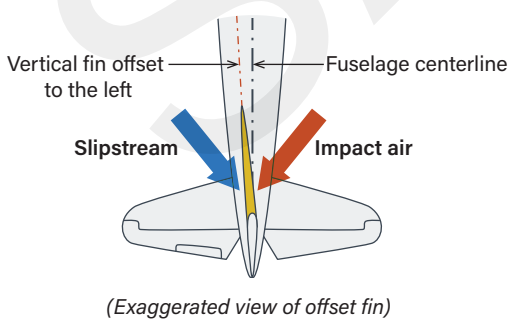
The airplane engine develops horsepower within its cylinders and, by rotating a propeller, exerts thrust. In straight and level, unaccelerated, cruising flight the thrust exerted (pounds) is considered to equal the drag (pounds) of the airplane.

You will hear a couple of terms concerning horsepower:

*Brake horsepower*—the horsepower developed at the crankshaft. In earlier times this was measured at the crankshaft by a braking system or absorption dynamometer known as a "prony brake." *Shaft horsepower* means the same thing. Your airplane engine is always rated in brake horsepower, or the power produced at the crankshaft. Brake horsepower and engine ratings will be covered more thoroughly in Chapter 23.



**Fig. 2-9.** The slipstream effect makes the airplane want to yaw to the left.



**Fig. 2-10.** The fin of this example airplane is offset to balance the yawing forces at cruise.

*Thrust horsepower*—the horsepower developed by the propeller in moving the airplane through the air. Some power is lost because the propeller is not 100 percent efficient, and for round figures, you can say that the propeller is at best about 85 percent efficient (the efficiency of the fixed-pitch propeller varies with airspeed). The thrust horsepower developed, for instance, will be only up to about 85 percent of the brake horsepower.

If you are mathematically minded, you might be interested in knowing that the equation for thrust horsepower (THP) is:  $THP = TV \div 550$ , where T is thrust (pounds) and V is velocity (feet per second) of the airplane. Remember that a *force* times a *distance* equals *work*, and when this is divided by time, *power* is found. In the equation above, *thrust* is the force, and velocity can be considered as being distance divided by time, so that TV (T × V) is power in foot-pounds per second. Knowing that 1 horsepower is 550 footpounds per second, the power (TV) is divided by 550 and the result would give the horsepower being developed—in this case, *thrust horsepower*. (See Chapter 9.)  $THP = TV \text{ mph} \div 375$ , or  $TV \text{ knots} \div 325$  (more about “knots” later).

For light trainers with fixed-pitch propellers, a measure of the power (brake horsepower) being used is indicated on the airplane’s tachometer in RPM (revolutions per minute). The engine power is controlled by the throttle. For more power the throttle is pushed forward or “opened”; for less power it is moved back or “closed.” You’ll use the throttle to establish certain RPM (power) settings for cruise, climb, and other flight requirements.

### Torque

Because the propeller is a rotating airfoil, certain side effects are encountered. The “lift” force of the propeller is the thrust used by the airplane. The propeller also has a drag force. This force acts in a sidewise direction (parallel to the wing span or perpendicular to the fuselage reference line).

The propeller rotates clockwise as seen from the flight deck, causing a rotating mass of air to be accelerated toward the tail of the airplane. This air mass strikes the left side of the vertical stabilizer and rudder. This air mass, called “slipstream” or “propwash,” causes the airplane to veer or “yaw” to the left. Right rudder must therefore be applied to hold the airplane on a straight track (Figure 2-9). This reaction increases with power, so it is most critical during the takeoff and climb portion of the flight. The slipstream effect is the biggest factor of torque for the single-engine airplane.

An offset fin may be used to counteract this reaction. The fin setting is usually built in for maximum effectiveness at the rated cruising speed of the airplane, since the airplane will be flying most of the time at cruising speed (Figure 2-10).



The balance of forces at this point results in no yawing force at all, and the plane flies straight with no right rudder being held.

Sometimes the fin may not be offset correctly due to tolerances of manufacturing, and a slight left yaw is present at cruising speed, making a constant use of right rudder necessary to hold the airplane straight. To take care of this, a small metal tab is attached to the trailing edge of the rudder and is bent to the left. The relative air pressure against the tab forces the rudder to the right (Figure 2-11).

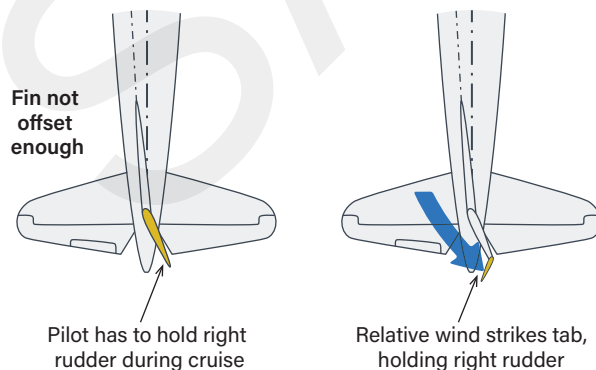
Since this change in the tab can only be accomplished on the ground, these are called ground adjustable trim tabs. The tab is bent, and the plane is test flown. This is done until the plane has no tendency to yaw in either direction at cruising speed. More on trim tabs in Chapter 8.

Assuming that you have the tab bent correctly and the plane is balanced directionally, what happens if you vary from cruising speed? If the same power setting of 2,400 RPM, for instance, is used, the arrows in Figure 2-12 show a simplified approach to the relative forces at various airspeeds.

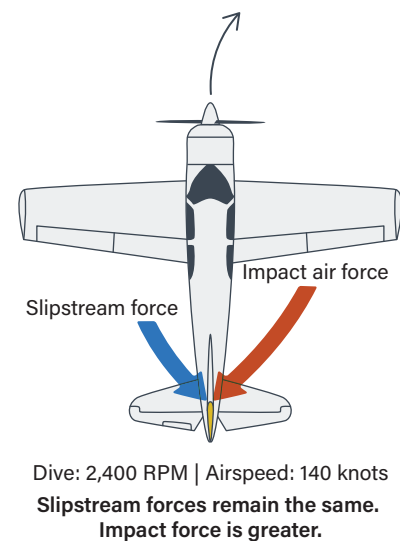
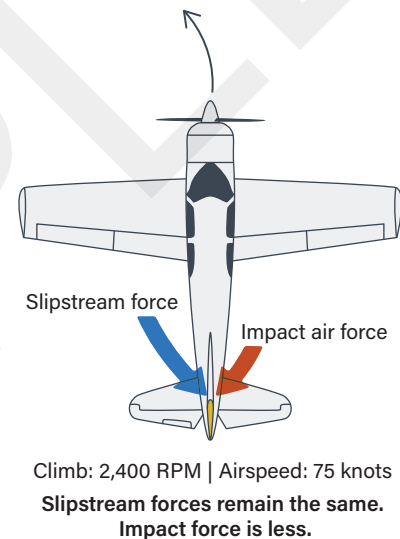
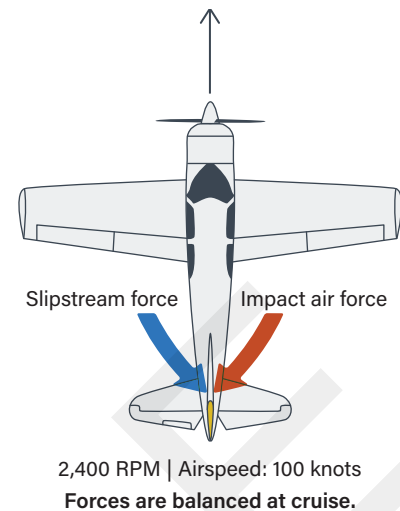
*In a climb, right rudder is necessary to keep the plane straight. In a dive, left rudder is necessary to keep it straight.*

In a glide there is considered to be no yawing effect. Although the engine is at idle and the torque effect is less, the airspeed is lower and the effect of the offset fin is also less.

Some manufacturers use the idea of “canting” the engine slightly so that the thrust line of the propeller (or crankshaft) is pointing slightly to the right. The correction for a left-yawing tendency at cruise is taken care of in this way rather than by offsetting the fin. In such installations, however, right rudder is still necessary in the climb and left rudder in a dive under the conditions shown in Figure 2-12.

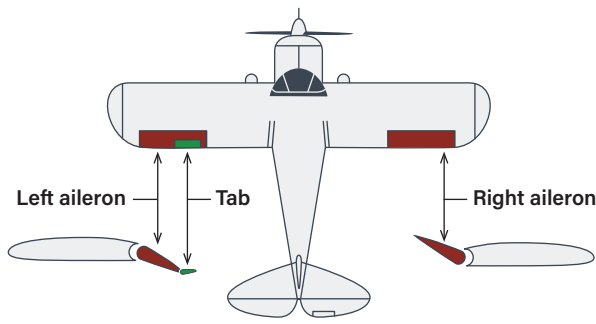


**Fig. 2-11.** The bendable rudder tab corrects for minor yaw problems at cruise. Some airplanes have a rudder tab that is controllable from the flight deck (See Chapter 8).

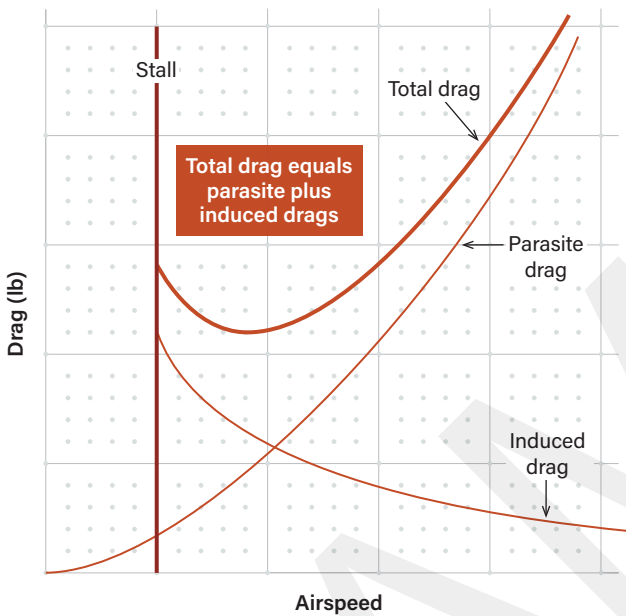


**Fig. 2-12.** A comparison of forces at various airspeeds (constant RPM).





**Fig. 2-13.** Your trainer may have a bendable tab on the aileron(s).



**Fig. 2-14.** The total drag of the airplane is made up of a combination of parasite and induced drag.

Another less important contributor to the “torque effect” is the tendency of the airplane to rotate in an opposite direction to that of the propeller (for every action there is an opposite and equal reaction). The manufacturer flies each airplane and “rigs” it, making sure that any such rolling tendency is minimized. They may “wash in” the left wing so that it has a greater angle of incidence (which results in a higher angle of attack for a particular nose attitude) than that of the right wing. This is the usual procedure for fabric-covered airplanes, resulting in more lift and more drag on that side. This may also contribute very slightly to the left yaw effect. In some airplanes, a small metal tab on one or both of the ailerons can be bent to deflect the ailerons as necessary, using the same principle described for the rudder tab (the tab makes the control surface move). The controls and their effects will be discussed in Chapter 8, and you may want to review this section again after reading that chapter. Figure 2-13 shows the ailerons and aileron tab.

Two additional factors that under certain conditions can contribute to the torque effect are gyroscopic precession and what is termed “propeller disk asymmetric loading” or “P factor.” Gyro precession acts *during* attitude changes of the plane, such as those that occur in moving the nose up or down or yawing it from side to side. Gyro precession will be discussed in Chapters 3 and 13. Asymmetric loading is a condition usually encountered when the plane is being flown at a constant, positive angle of attack, such as in a climb or the tail-down part of the tailwheel airplane takeoff roll (Chapter 13). The downward-moving blade, which is on the right side of the propeller arc as seen from the flight deck, has a higher angle of attack and higher thrust than the upward-moving blade on the left. This results in a left-turning moment.

Actually the problem is not as simple as it might at first appear. To be completely accurate, a vector system including the propeller angles and rotational velocity and the airplane’s forward speed must be drawn to get a picture of the exact angle of attack difference for each blade. In other words, if the plane is flying at an angle of attack of 10°, this *does not* mean that the downward-moving blade has an effective angle of attack 10° greater than normal and that the upward-moving blade has an effective angle 10° less than normal, as might be expected.

From a pilot's standpoint, you are only interested in what must be done to keep the plane straight. When speaking of "torque," the instructor is including such things as the rotating slipstream, gyroscopic effects, asymmetric disk loading (*P* factor), and any other power-induced forces or couples that tend to turn the plane to the left.

## Drag

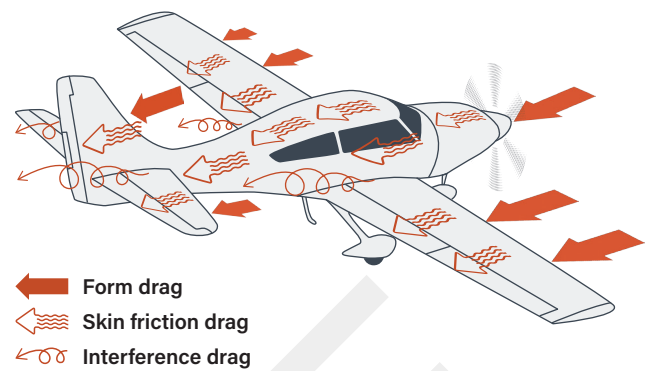
Anytime a body is moved through a fluid (such as air), drag is produced. Drag acts parallel to and in the same direction as the relative wind. The "total" drag of an airplane is composed of two main types of drag, as shown by Figure 2-14.

*Parasite drag* (Figure 2-15)—the drag composed of (1) "form drag" (the landing gear and radio antennas, the shape of the wings, fuselage, etc.), (2) skin friction, and (3) airflow interference between components (such as would be found at the junction of the wing and fuselage or fuselage and tail). As the word "parasite" implies, this type of drag is of no use to anybody and is about as welcome as any other parasite. However, parasite drag exists and it's the engineer's problem to make it as small as possible. Parasite drag increases as the square of the airspeed increases. Double the airspeed and parasite drag increases *four* times. Triple the airspeed and parasite drag increases *nine* times.

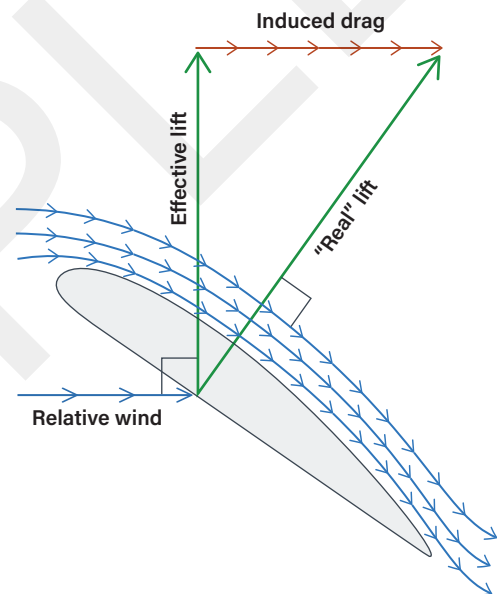
*Induced drag*—the drag that results from lift being produced. The relative wind is deflected downward by the wing, giving a rearward component to the lift vector called *induced drag* (the lift vector is tilted rearward—see Figure 2-16). The air moves over each wing tip toward the low pressure on the top of the wing and vortices are formed that are proportional in strength to the amount of induced drag present. The strength of these vortices (and induced drag) increases radically at higher angles of attack so that the *slower* the airplane flies, the *much greater* the induced drag *and* vortices will be (Figures 2-14, 2-16, and 2-17).

## Weight

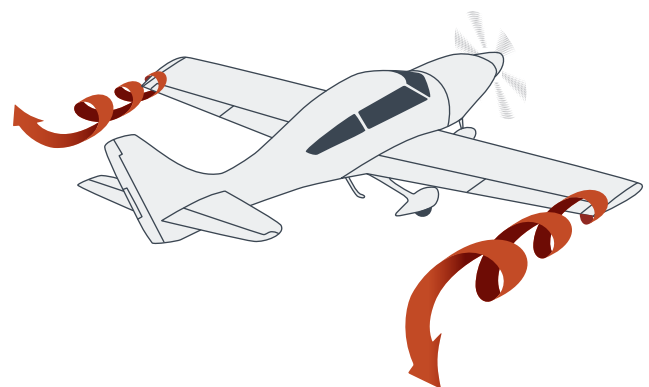
Gravity is like the common cold, always around and not much that can be done about it. This can be said, however: Gravity always acts "downward" (toward the center of the earth). Lift does not always act opposite to weight, as you will see in Chapter 9.



**Fig. 2-15.** Parasite drag.



**Fig. 2-16.** Induced drag.



**Fig. 2-17.** Wing tip vortices.



---

Part

**3**

Postsolo  
Maneuvers

SAMPLE



## ADVANCED STALLS

### Cross-Control Stall/Skidding

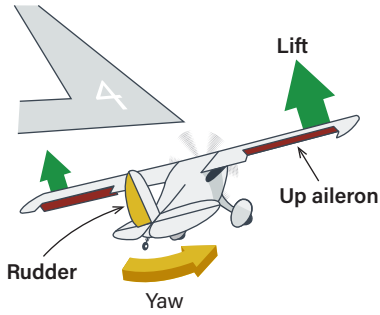
This stall is a perfect illustration of the dangers of abusing the controls. A typical case of a cross-control stall accident is this: A pilot sees in the turn onto final that it will require a sharper turn to line up with the runway. (Look at Figures 13-38, 13-39, and 13-40 again.) Pilots have always been told the dangers of banking too steeply at low altitude, so to avoid this and still make the turn, they do something much worse.

A small voice inside says, “Go on, use rudder, skid it around and you won’t have to bank it.”

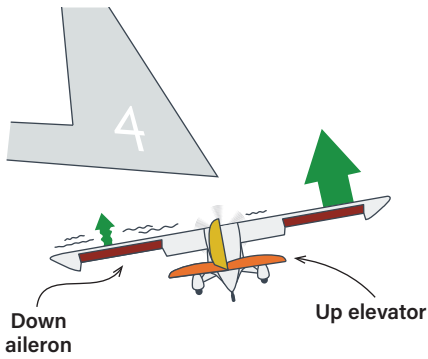
So, the pilot skids it. As you know full well, when a plane is skidded, the outside wing speeds up, gets more lift than the inside one, and the plane starts to increase its bank. The pilot realizes this and unconsciously holds aileron against the turn. The down aileron on the inside of the turn helps drag that wing back more, slowing it up and decreasing the lift, which requires more aileron to hold it up—and so the cycle goes. As the plane is banked, use of bottom rudder and opposite aileron will tend to cause the nose to drop. The pilot helpfully holds more back pressure to keep the nose up. This, then, is the perfect setup for one wing to stall before the other. Figures 14-1 through 14-4 show the maneuver as seen from outside the airplane and from the flight deck.



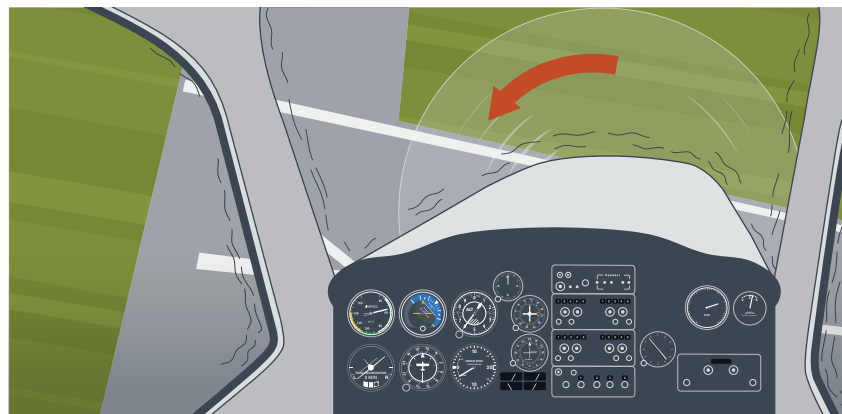
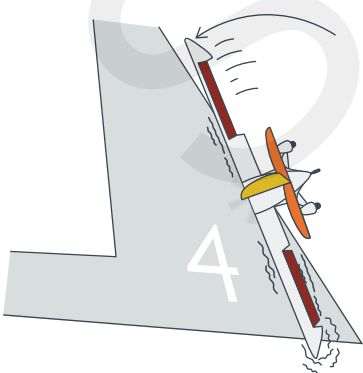
**Fig. 14-1.** Pilot sees that the plane will fly past the runway if the rate of turn is not increased.



**Fig. 14-2.** The pilot doesn't want to make a steep bank at low altitude, knowing that the stalling speed increases with angle of bank, so applies the rudder to cheat a little. Lift is greater on the outside wing because of its increased speed. The bank starts to increase because of the difference in lift. The pilot doesn't want the bank any steeper, so opposite aileron is applied.



**Fig. 14-3.** The nose tends to drop because of rudder and aileron, so up-elevator is added. Down-aileron drags the wing back causing a steeper bank. More opposite aileron is applied, etc.



**Fig. 14-4.** The inside wing stalls and the plane rotates abruptly toward the low wing. *The altitude is insufficient for recovery.*

The practice cross-control stall (at a safe altitude) is aimed at teaching you to recognize how such a stall occurs and giving you practice in effectively recovering from such a situation. The cross-control stall, like any other, can occur at any speed, altitude, or power setting.

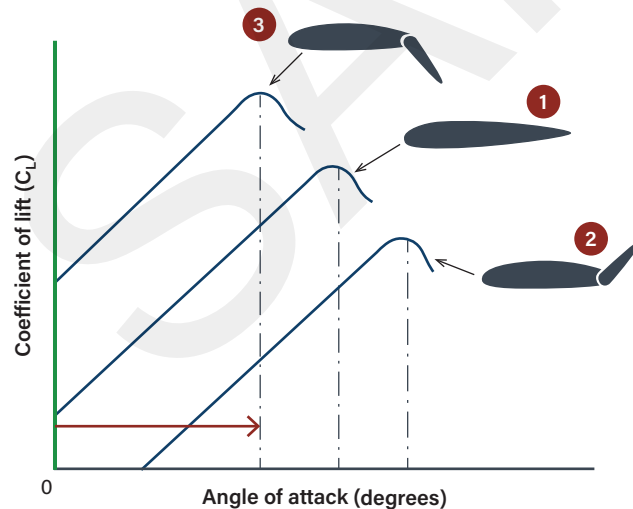
The bad thing about this skidding stall is that the forces working on you as it is being approached are “normal.” That is, you’ll feel pushed to the outside of the turn (as is the case every time you make a turn in a car), so you may not be warned of impending trouble.

Figure 14-5 shows why the inside wing (with the down aileron) tends to stall first when, by “common sense,” the down aileron should hold that wing up.

Looking back at Figure 12-12, you can see the effect on the coefficient-of-lift curve of extended flaps. A down aileron will give the same general effect (although it’s farther out on the wing, so when it stalls the rolling moment will be greater). The up aileron (2) in Figure 14-5 has the effect of the wing being twisted to a lower angle of incidence and a resultant higher-than-normal critical angle of attack.

As you increase the angle of attack, as indicated by the red arrow in Figure 14-5, the inside wing with the down aileron (3) will reach its “break” first and will stall. The question comes up: Shouldn’t there be more lift on that wing and therefore no stall? By a bizarre arrangement of the controls to stop the airplane from rolling into a steeper bank, the pilot is assuring that the actual lift of each wing (in pounds) is equal to the other. And since angle of attack is the only criterion of the stall, that inside wing goes first.

A situation that increases the likelihood of this stall is when the traffic pattern has a tailwind on the base leg. If



**Fig. 14-5.** Coefficient of lift versus angle of attack for three conditions: (1) airfoil with no aileron or flap deflection, (2) the right wing (aileron up), and (3) the left wing (aileron down).

the windsock, flag, or weather reporting system shows the runway has a headwind on landing but a tailwind component on base (Figure 13-31), be sure to fly your pattern wide enough that you can still make a shallow-banked turn from base to final (you’ll be starting the turn early). If the wind is a direct crosswind, seriously consider landing in the direction (traffic permitting) that will give you a headwind on base, even if you have to overfly the field to join the pattern from the far side. A couple of minutes of extra flying in this case can avoid a more skill-intensive traffic pattern.

## Procedure—Power-Off

1. This is a turning stall, so the clearing turns are not necessary. Keep looking around during the stall.
2. Pull the carburetor heat ON and make a shallow gliding turn. (The direction of turn will be left up to you—practice them in both directions.)
3. Gradually apply more and more inside rudder to “cheat” on the turn.
4. Use opposite aileron as necessary to keep the bank from increasing.
5. Keep the nose up by increasing back pressure.
6. When the break occurs, neutralize the ailerons. Stop any further rotation with opposite rudder. Relax back pressure.
7. Roll out of the bank with coordinated controls.

The rotation toward that inside wing is so fast that it is quite possible that the bank will be vertical or past vertical before it is stopped.

In many ways the recovery from this stall is close to the recovery from a spin. The lift of the wings must be made equal. This is done by neutralizing the ailerons and stopping further rotation with rudder *at the same time* as back pressure is released. The neutralizing of the ailerons speeds the equalizing of lift.

Because of the low position of the nose when the rotation is stopped, the speed will build up quickly. Recover to straight and level flight with coordinated controls as soon as possible without overstressing the plane or getting a secondary stall.

## Common Errors

1. Not neutralizing the ailerons at the start of the recovery.
2. Using too much opposite (top) rudder to stop rotation, causing the plane to slip badly during the recovery.
3. Waiting too long to roll out with coordinated controls and delaying pull up; too great an altitude loss.



Cross-control stalls, as such, are not required on the private practical (flight) test but were included here to show the hazards of trying to “cut corners” and the effects of neglecting coordination at critical times.

Your instructor may have you practice these stalls (dual only) using flaps or having the airplane in the clean configuration. Naturally if flaps are used, the instructor will be responsible for retracting them after the stall breaks to avoid exceeding the flaps-extended airspeed ( $V_{FE}$ )—the maximum value (top) of the white arc.

A suggested procedure is to make the turn onto base with a 30° bank. This gives an earlier roll-out on base that allows a check of the runway and for airplanes on straight-in approaches. A 30° bank only raises the stall speed of *any* airplane by a factor of 1.07, or 7 percent.

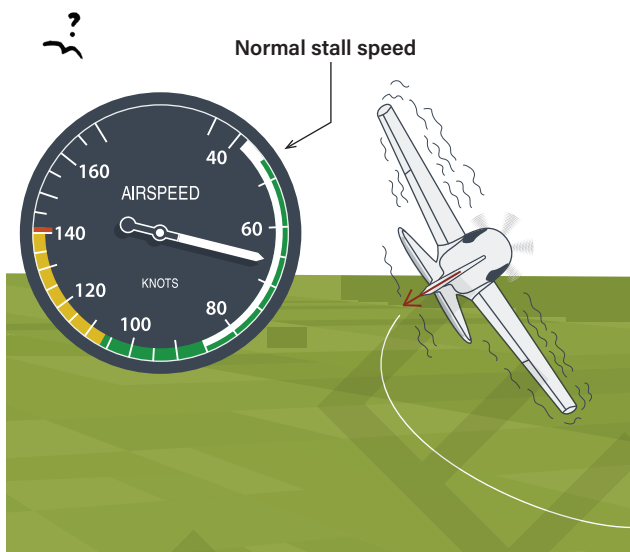
## Accelerated Stalls

The accelerated stall is a maneuver for proving that the stall is a matter of angle of attack, not airspeed. The accelerated stall is to be started no higher than 1.25 times the normal stalling speed because of extra stresses that may be put on the plane by stalling at higher speeds. The term “accelerated” means that the airplane is under forces of acceleration, or G forces, when the stall occurs.

Chapter 9 “The Turn” introduced the expression “load factor.” In the 60° banked turn (constant altitude) the load factor was 2, or the airplane was subjected to 2 Gs. As far as the wings were concerned, the airplane weighed twice as much. By working out the math it was shown that the stall speed was increased by the square root of the load factor, which turned out to be 1.414. In the 60° banked turn, the airplane stalled at a speed over 41 percent higher than normal stall speed. The same increase in stall speed effect would have occurred if you had loaded the plane to *twice* its normal weight and done an old-fashioned straight-ahead stall. (Don’t load it that way!)

The pilot in Figure 14-6 can’t understand why evidence of a stall shows up when the airspeed is so high. (In a 60° banked constant-altitude turn, the stall speed is increased by a factor of 1.414, from 47 to 66 kt. The pilot is feeling a load factor of 2 Gs.)

You can also encounter positive acceleration forces when pulling up from dives or brisk pull-ups from straight and level; acceleration doesn’t just happen in a turn, although in everyday flight, this is the most likely place to meet it. Of course, you could run into strong negative acceleration forces (or negative Gs) if you were to shove the yoke forward abruptly at high speeds. (Don’t do *that* either!) You’ve been used to thinking of acceleration in terms of increasing speed. This is not the type of acceleration of interest here.



**Fig. 14-6.** The stall is a function of angle of attack not airspeed. This pilot is learning that the load factor is 2 Gs and the stall speed in a 60° banked level turn is 1.414 times that of normal 1 G flight.

Your elevators are not only the airspeed control but are also your G control. By rapidly pulling back on the yoke or stick, positive G forces are created. (They may be too positive at speeds well above the stall, and problems could result.) Pulling back abruptly means that excess lift is temporarily in existence. The airplane will start slowing immediately to reestablish the old lift value (*the airplane always tends to remain in equilibrium as far as lift and weight are concerned*). You may, however, exceed the airplane’s limit load factor (maximum allowed Gs) before the airplane has a chance to slow and equilibrium can be established. Normal category airplanes are required to have a maximum limit load factor of 3.8 positive and 1.52 negative Gs. Utility category planes have limit load factors of 4.4 positive and 1.76 negative Gs. Your trainer will fall into one of these two categories. If you pulled hard enough to stall the airplane at twice normal stall speed, you’d pull 4 Gs (2 squared is  $2 \times 2 = 4$  Gs). And this would be over the limit for a normal category airplane. (A more complete explanation of the various category requirements will be covered in Chapter 23.) If you pulled hard enough to stall the airplane at three times the normal stall speed, 9 Gs would result (3 squared = 9), and you would be flying a wingless—or tailless—wonder.

The stalls you’ve done up to now have been at a normal load factor of 1 G. You *gradually* increased the angle of attack until the stall occurred.

# The Student Pilot's Flight Manual

From First Flight to Pilot Certificate

A ground school textbook, maneuvers manual, and syllabus all rolled into one, *The Student Pilot's Flight Manual* provides a step-by-step comprehensive course for student pilots working towards a Private or Sport Pilot Certificate. This authoritative volume from the legendary flight instructor William K. Kershner, edited by his son, William C. Kershner, presents a wealth of practical information, while encouraging student pilot decision making. The fundamentals of flying are clearly described in a methodical yet informal manner that a learner can easily absorb, including detailed references to maneuvers and procedures and fully illustrated, featuring the author's original drawings.

This manual covers everything you need to know for your first flight, presolo, post-solo maneuvers, cross-country, and night flying. First published in 1960 and updated continuously since then, this new 12th Edition features color figures and enhanced instruction to ensure you will be prepared for the classroom, tarmac, and flight deck.

A gathering of material used in preflight and postflight briefings accompanies in-flight instruction, all provided by one of the greatest flight instructors of our time. A synopsis of what to expect for your FAA Knowledge Exam and checkride will reassure any student or renewing pilot. Intended to do more than help you "get past" the exam and checkride—this book also features the essential information used in the day-to-day processes of flying airplanes.

With over six decades of experience as pilot-in-command flying more than 100 types and models of airplanes, Bill Kershner was FAA/General Aviation Flight Instructor of the Year in 1992 and then named Elder Statesman of Aviation in 1997. He was inducted into the Flight Instructor Hall of Fame in 1998. His son, William C. Kershner, who edited and updated this volume, was soloed by his father and holds Flight Instructor and Airline Transport Pilot Certificates. Across his more than 15,000 hours of flight time, he has flown 22 types of airplane, ranging from Cessna 150s to Boeing 777s.



**Aviation Supplies & Academics, Inc.**  
7005 132nd Place SE  
Newcastle, Washington 98059 USA  
425-235-1500 | asa2fly.com

ASA-FM-STU12

*"Since I first began taking flying lessons, I have used William Kershner's wonderful Flight Manuals—from his Student Pilot's Flight Manual to his Flight Instructor's Manual. I love the way Mr. Kershner makes fun and interesting reading of sometimes dry subjects. His books are easy and fun to read and filled with all of the best information! I continue to recommend his books to anyone learning to fly and have bought quite a few of them over the years to give to aspiring pilots. I cannot think of any other books on aviation that I would recommend more highly than William Kershner's Flight Manuals."*

Patty Wagstaff  
2004 Inductee  
National Aviation Hall of Fame

TRANSPORTATION USD \$49.95

ISBN 978-1-64425-408-0



9 781644 254080