

Manifold Pressure (M-1)

Operating and Installation Instructions

OI 0517912

5/17/91
Rev. C: 9/30/97

You must read this manual before installing or operating the instrument. This manual contains warranty and other information that may affect your decision to install this product and/or the safety of your aircraft.



S/N: _____



Electronics International Inc. ®

63296 Powell Butte Hwy • Bend, OR 97701 • (541) 318-6060 • Buy-El.com 

Important Notice

***** MUST READ *****

If you think it is not important to read this manual, you're wrong! This manual contains important installation information that may affect the safety of your aircraft, delay your installation or affect the operation of your instrument. You Must read this manual prior to installing your instrument. Any deviation from these installation instructions is the sole responsibility of the installer/pilot and may render the STC invalid.

Read the Warranty / Agreement. There is information in the Warranty / Agreement that may alter your decision to install this product. If you do not accept the terms of the Warranty / Agreement, do not install this product. This product may be returned for a refund. Contact Electronics International inc. for details.

Check that the instrument make and model marked on the side of the instrument and on the invoice are correct before starting the installation.

Check that the limit information on this instrument matches the published limits in your aircraft's P.O.H. or Flight Manual. Also, this information may be listed in the T.C. Data Sheet for your aircraft. Any AD's and/or STC's may set forth additional limitations on the operation of your engine. The limit information listed in the AML is for unmodified aircraft and is intended for reference only. It is the aircraft owner's and/or installer's responsibility to determine proper instrument calibration and range markings for your aircraft.

On the front of this instrument you will find a red light marked with the maximum manifold pressure information. If there are any additional red or yellow lights on this instrument, the operating range of these lights can be found on a sticker located on the side of the instrument (see the AML at the back of this manual to decode this information). This instrument designates any "Caution Range" with yellow LEDs, any "Maximum and Minimum Limits" with Red LEDs and the "Safe Operating Range" with green LEDs. The "Safe Operating Range" on this instrument is equivalent to the green "Normal Operating Range" and any unmarked areas on a analog gauge.

It is possible for any instrument to fail thereby displaying inaccurate high, low or jumpy readings. Therefore, you must be able to recognize an instrument failure and you must be proficient in operating your aircraft safely in spite of an instrument failure. If you do not have this knowledge, contact the FAA or a local flight instructor for training.

The pilot must understand the operation of this product before flying the aircraft. Do not allow anyone to operate the aircraft that does not know the operation of this product. Keep the Operating Manual in the aircraft at all times.

Contents

Warranty	2
Operation Instructions	3
Instrument:	3
Analog Display:	3
Digital Display:	3
Installation Instructions	4
Important Information and Initial Check Out:	4
Route The Circular Connector:	5
Route the Power and Ground Wires:	5
Route the Backlight Wires:	5
Route the (Optional) External Warning Control Line:	6
Install the Instrument in the Panel:	6
Connect the Circular Connector to the Instrument:	6
Connect the Manifold Pressure Line:	6
Check Instrument Operation:	7
Wiring Diagram	8
M-1 Circular Connector	9
Specifications and Operating Features	10
STC Information	11

Warranty / Agreement

Electronics International Inc. warrants this instrument and system components to be free from defects in materials and workmanship for a period of one year from the user invoice date. Electronics International Inc. will repair or replace any item under the terms of this Warranty provided the item is returned to the factory prepaid.

1. This Warranty shall not apply to any product that has been repaired or altered by any person other than Electronics International Inc., or that has been subjected to misuse, accident, incorrect wiring, negligence, improper or unprofessional assembly or improper installation by any person. This warranty does not cover any reimbursement for any person's time for installation, removal, assembly or repair. Electronics International retains the right to determine the reason or cause for warranty repair.
2. This warranty does not extend to any machine, vehicle, boat, aircraft or any other device to which the Electronics International Inc. product may be connected, attached, interconnected or used in conjunction with in any way.
3. The obligation assumed by Electronics International Inc. under this warranty is limited to repair, replacement or refund of the product, at the sole discretion of Electronics International Inc.
4. Electronics International Inc. is not liable for expenses incurred by the customer or installer due to factory updates, modifications, improvements, upgrades, changes, or any other alterations to the product that may affect the form, fit, function or operation of the product.
5. Personal injury or property damage do to misinterpretation or lack of understanding this product is solely the pilots responsibility. The pilot must understand the operation of this product before flying the aircraft. Do not allow anyone to operate the aircraft that does not know the operation of this product. Keep the Operating Manual in the aircraft at all times.
6. E. I. Inc. is not responsible for shipping charges or damages incurred under this Warranty.
7. No representative is authorized to assume any other liability for Electronics International Inc. in connection with the sale of Electronics International Inc. products.
8. If you do not agree to and accept the terms of this warranty, you may return the product for a refund.

This Warranty is made only to the original user. THIS WARRANTY IS IN LIEU OF ALL OTHER WARRANTIES OR OBLIGATIONS: EXPRESS OR IMPLIED. MANUFACTURER EXPRESSLY DISCLAIMS ALL IMPLIED WARRANTIES OF MERCHANTABILITY OR FITNESS FOR A PARTICULAR PURPOSE. PURCHASER AGREES THAT IN NO EVENT SHALL MANUFACTURER BE LIABLE FOR SPECIAL, INCIDENTAL OR CONSEQUENTIAL DAMAGES, INCLUDING LOST PROFITS OR LOSS OF USE OR OTHER ECONOMIC LOSS. EXCEPT AS EXPRESSLY PROVIDED HEREIN, MANUFACTURER DISCLAIMS ALL OTHER LIABILITY TO PURCHASER OR ANY OTHER PERSON IN CONNECTION WITH THE USE OR PERFORMANCE OF MANUFACTURER'S PRODUCTS, INCLUDING SPECIFICALLY LIABILITY IN TORT.

Operation Instructions

M-1

0517932

Instrument:

The M-1 is a precision manifold pressure instrument featuring a 210 degree analog display and a digital display. These two displays have many advantages over conventional analog gauges as described below.

Also, the M-1 features long-term accuracy and reliability. Since the M-1 does not incorporate any moving parts (needles, bearings, springs, etc.) there is little to go wrong or wear out. The internal microprocessor assures accuracy and repeatability.

Analog Display:

The 210 degree analog display provides a quick reference of manifold pressure with respect to its operating range. At a glance you can get a relative idea of where in the range you are operating the engine and how close to the maximum limit you are. Precise information is provided in the digital display.

An advantage of the analog display is its ability to emit a green, yellow or red light. With a quick glance you can determine if you're operating in a normal, caution or restricted range. Also, when you exceed a maximum limit the red light will blink 20 times at full intensity to catch your attention and warn you that a maximum limit has been violated. After 20 blinks the red light will stop blinking and display continuous red so it does not distract you.

During night operation the analog lights may be too bright. If so, turn the panel light rheostat up and the analog lights will dim. The red (maximum limit) light will always be displayed at full intensity.

Digital Display:

The M-1 measures absolute atmospheric pressure in the engine's manifold to .1 inches of mercury. This reading should not be confused with barometric pressure. Barometric pressure readings are altitude compensated to sea level. For every 100 feet above sea level there is approximately .1 inches of mercury less manifold pressure available to the engine. That means at 1000 feet above sea level with a barometric reading of 30.0 inches of mercury, the maximum manifold pressure available for a non-turbocharged aircraft is 29.0 inches of mercury. Less manifold pressure means less power.

Two other factors affecting manifold pressure are induction loss and ram air. Induction loss is the normal drop in pressure across the carburetor and intake manifold. This will lower your available manifold pressure by approximately 1.0 inches of mercury. Ram air, on the other hand, will increase your manifold pressure. Ram air is the normal compression of air in the manifold caused by airspeed and dependent on the location of the intake air pickup point. At 145 knots the maximum increase in manifold pressure available is 1.0 inches of mercury.

The M-1 can detect a change in manifold pressure for every 100 feet of elevation or .1 inches change in barometric pressure. This allows for precise setting and monitoring of the manifold pressure.

If the digital display backlight has been permanently powered up (as recommended), the digital display will be easier to see during low ambient light conditions and at night.

Installation Instructions

M-1

Important Information and Initial Check Out:

1. The installer and aircraft owner must read the Warranty before starting the installation. There is information in the Warranty that may alter your decision to install this instrument. If you do not accept the terms of the Warranty, do not install this instrument.
2. If you are not an FAA Certified Aircraft Mechanic familiar with the issues of installing aircraft manifold pressure instruments, Do Not attempt to install this instrument. The installer should use current aircraft standards and practices to install this instrument (refer to AC 43.13).
3. Check that any necessary FAA Approvals (STC's, etc.) are available for your aircraft before starting the installation. The FAA Approved Model List (AML) is located at the back of this manual. Resolve any issues you may have before starting the installation.
4. Before starting the installation, read the entire Installation Instructions and resolve any issues you may have. This may eliminate any delays once the installation is started.
5. Check that the instrument make and model marked on the side of the instrument and on the invoice are correct before starting the installation.
6. Check that the limit information on this instrument matches the published limits in your aircraft's P.O.H. or Flight Manual. Also, this information may be listed in the T.C. Data Sheet for your aircraft. Any AD's and/or STC's may set forth additional limitations on the operation of your engine. The limit information listed in the AML is for unmodified aircraft and is intended for reference only. It is the aircraft owner's and/or installer's responsibility to determine proper instrument calibration and range markings for your aircraft.

On the front of this instrument you will find a red light marked with the maximum manifold pressure information. If there are any additional red or yellow lights on this instrument, the operating range of these lights can be found on a sticker located on the side of the instrument (see the AML at the back of this manual to decode this information). This instrument designates any "Caution Range" with yellow LEDs, any "Maximum and Minimum Limits" with Red LEDs and the "Safe Operating Range" with green LEDs. The "Safe Operating Range" on this instrument is equivalent to the green "Normal Operating Range" and any unmarked areas on a analog gauge.

Do not attempt to remove or replace the limit stickers on this instrument. If the manifold pressure limits for your engine do not match those which are marked on this instrument send this unit back to Electronics International Inc. for recalibration. DO NOT install or use a primary engine instrument that is not properly calibrated for your aircraft.

7. Before starting the installation make sure the unit will fit in the location you intend to install it without obstructing the operation of any controls.
8. If this instrument is to replace an existing unit in the aircraft, it is the installer's responsibility to move or replace any existing instruments or components in accordance with FAA approved methods and procedures. The following Installation Instructions do not cover moving or the removal of any existing instruments or components.

Route The Circular Connector:

Starting from under the instrument panel, route the circular connector wire harness up to the instrument mounting location. (See the wiring diagram at the back of this manual). Place the circular connector about 8 inches back from the panel. Tie wrap the harness in place approximately 1 foot back from the circular connector. This will allow the harness to be flexible and accommodate varying lengths in instrument wires. Be sure these wires do not obstruct the freedom of travel of any controls.

Route the Power and Ground Wires:

Route the red wire in the harness to the aircraft's 12 or 24 volt main or emergency bus as applicable via an independent circuit breaker (five amps or less). An alternate method would be to route the red lead to the bus via a one amp in-line fuse. With this method a spare fuse should be kept in the aircraft.

Route the black wire in the harness to a good ground . Tie wrap these wires so they do not obstruct the freedom of travel of any controls.

Route the Backlight Wires:

Connect the backlight wires as follows:

1. It is recommended to permanently power up the digital display backlight.
 - a) For a 12-volt system connect the white/brown wire to the instrument Red Power Lead. Connect the white/red wire to ground (see Wiring Diagram).
 - b) For a 24-volt system leave the white/brown open. Connect the white/red wire to the instrument Red Power Lead (see Wiring Diagram).
2. Connect the white/orange wire to the panel light rheostat. This wire will dim the analog LED's for night operation when the panel lights are turned on. If this line is left open, the analog LED's will remain at full intensity at all times. Also, if the voltage on this line drops below 11.5 volts, the analog LED's will be displayed at full intensity. Tie wrap all wires so they do not obstruct the freedom of travel of any controls.

Route the (Optional) External Warning Control Line:

The white/yellow wire can be connected to an external light (AL-1), buzzer (ATG-1), voice annunciator (AV-17), a relay, etc. This wire grounds when the red warning light is on. The current in this line must be limited to 2/10 of an amp maximum. Exceeding this limit will damage the unit. If this feature is not used, leave this line open. Tie wrap this wire so it does not obstruct the freedom of travel of any controls.

Install the Instrument in the Panel:

Install the instrument from behind the instrument panel using 6 x 32 screws. These screws should not be any longer than 1/2".

Connect the Circular Connector to the Instrument:

- 1) Push the two mating connectors together and twist them until they snap into position.
- 2) Turn the locking ring on the instrument connector clockwise (1 1/2 turns) until it locks into position.

Connect the Manifold Pressure Line:

Connect the aircraft manifold pressure line to the pressure port on the back of the instrument. Be sure this line is tight. This pressure port is a 1/4" flare union and is standard for most manifold pressure gauges. Care should be taken not to put excess pressure on the flexible line between the flare union and the pressure transducer mounted on the back of the instrument. The Pressure Transducer Port can break. Make sure the flexible pressure line does not have any kinks.

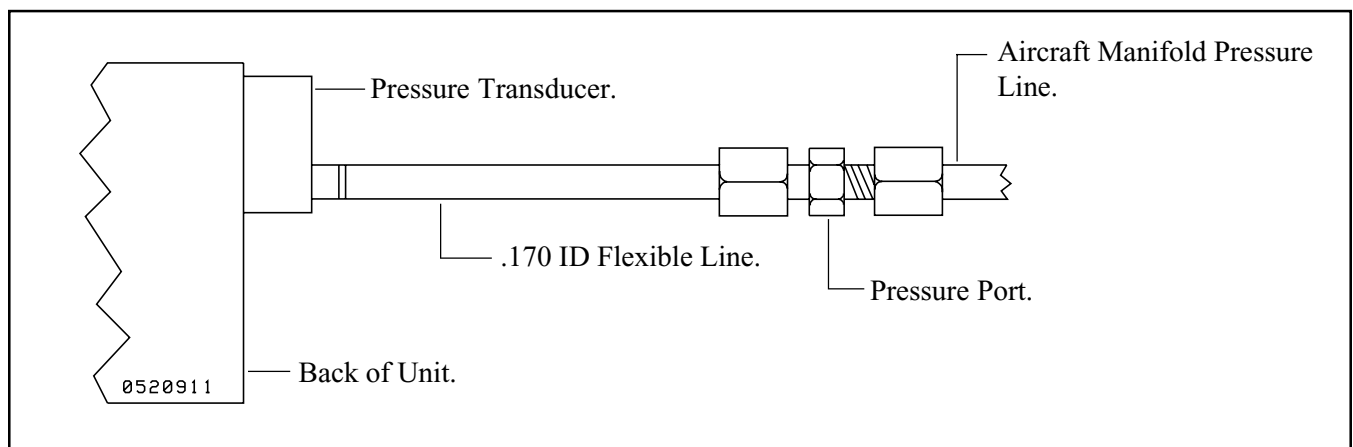

Check Instrument Operation:

Check instrument operation as follows:

1. Turn the master switch on (engine off) and verify that the instrument sequences through all the analog lights and reads approximately barometric pressure less .1 inches of mercury for every 100 feet you are above sea level. A problem at this step could be caused by poor connections on the red and/or black leads.
2. Check the digital display backlight. With high or medium ambient light it is hard to see the digital display backlight (it is only required during low ambient light conditions but should be on all the time).
3. Start the aircraft engine and check the digital and analog display to read properly. A problem at this step could be caused by a restriction or leak in the manifold pressure line. Never pressurize this line with the M-1 connected. This will damage the pressure transducer.

Manifold Pressure (M-1) Wiring Diagram

WD 0313911

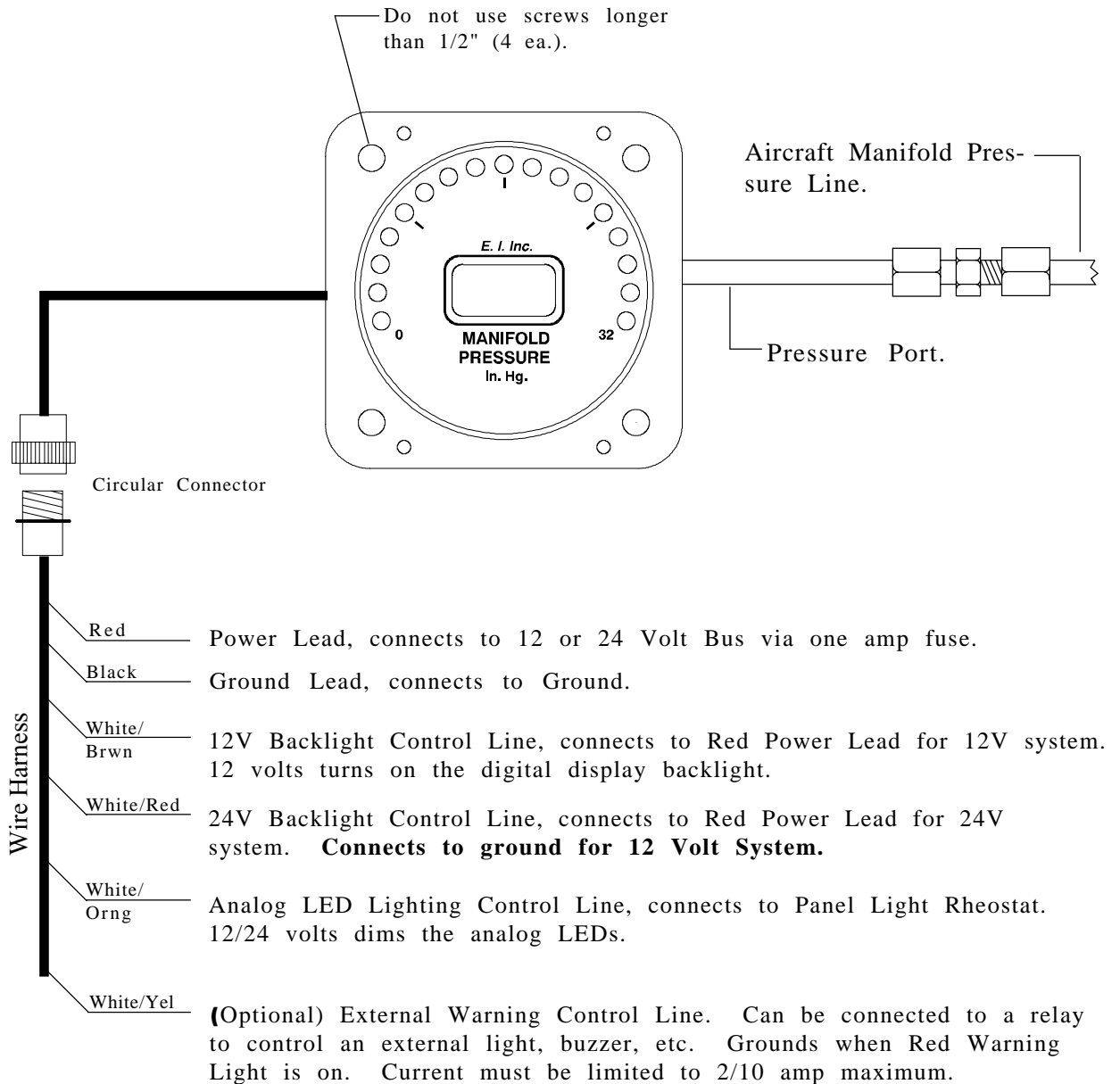

M-1 Circular Connector

Connecting Cable Harness, Back View (wire side)

OR

Instrument Connector, Front View

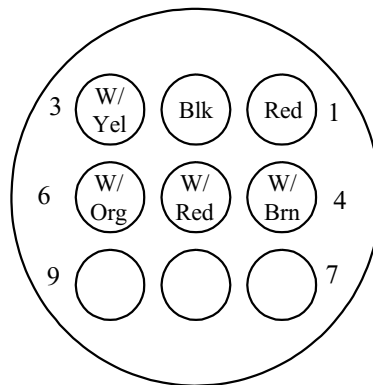

Note: See Wiring Diagram for hook up information.

Specifications and Operating Features

S0515911

5/15/91

Model:

M-1 (Manifold Pressure Instrument)

Case Dimensions:

2.5" x 2.5" x 3.65" depth, 2 1/4" Bezel.

Weight:

13 Oz.

Environmental:

Meets TSO C45.

Power Requirements:

7.5 to 30 Volts, 1/10 Amp.

Analog Display:

17 High Intensity Light Emitting Diodes (LEDs) in a 210 degree arc with Intensity Control Line available for dimming. Sequential flash test on power up. Microprocessor eliminates LED hunting (flicker).

Red LEDs:

If the Analog Display goes from a Green LED or Yellow LED to a Red LED, the Red LED will blink 20 times then go solid red.

Digital Display:

LCD (viewable in direct sunlight), with 12 and 24 volt backlight control wires for night operation. Displays "888" on power up.

Accuracy:

1% in accordance with TSO C45.

Resolution:

.1 In. Hg.

Max Range:

Max Allowable: 60 In. Hg.

Update Time:

3 times per second.

Pressure Port:

1/4 inch male flare union mounted on a .170 I.D. flexible tube located on the back of the unit.

External Warning Control Line:

Grounds when any Red Warning Light is on or blinking. Current should be limited to 2/10 amp.